



Air-Carriages for Microgravity Testbeds

Sujet Phodapol

Scope & Motivation

- **Scope - DISCOWER:** Develop algorithm for safe control and planning on weightless environments
- **This project:** Develop a flexible air carriage for testing of microgravity system:
 - Reliable platform for satellite/free flyer testing
 - Easily replicable and build
 - Actuation for active mass and inertia compensation

Related works



MIT SPHERE free-flyer robot and the air-carriage system

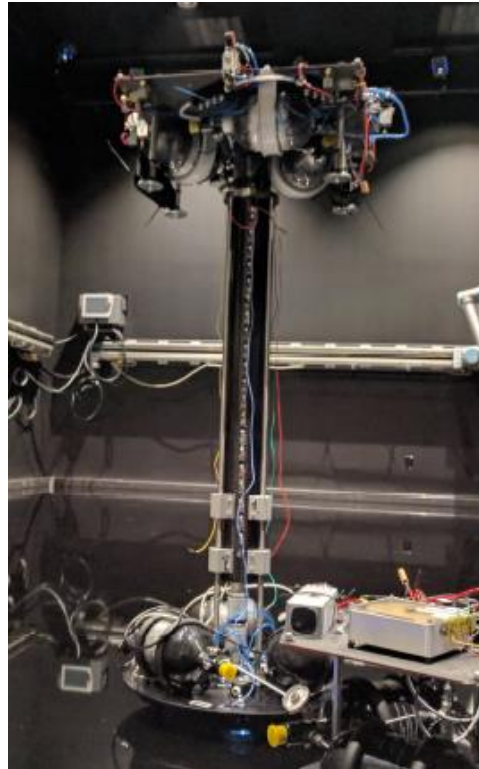

A SIX DEGREE-OF-FREEDOM SPACECRAFT,
California Institute of Technology

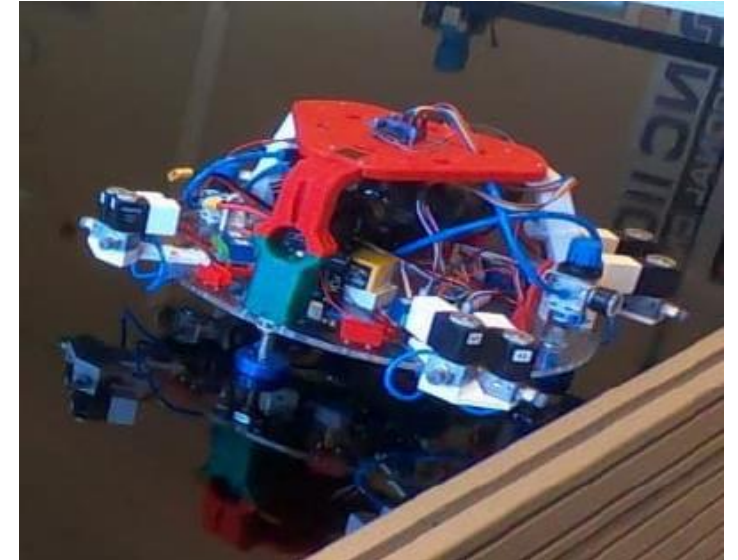

Slider, Luleå University of Technology,

Related works

Other Robots

- Complex
- Large
- Short operation time



Our goal

- Simple
- Small
- Long operation time
- Refillable
- Actuation for mass and inertia compensation

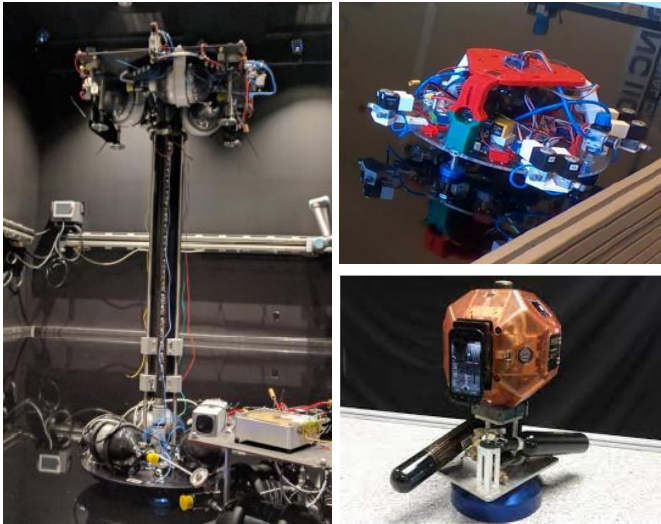

Related works

Other Robots

- Complex
- Large
- Short operation time

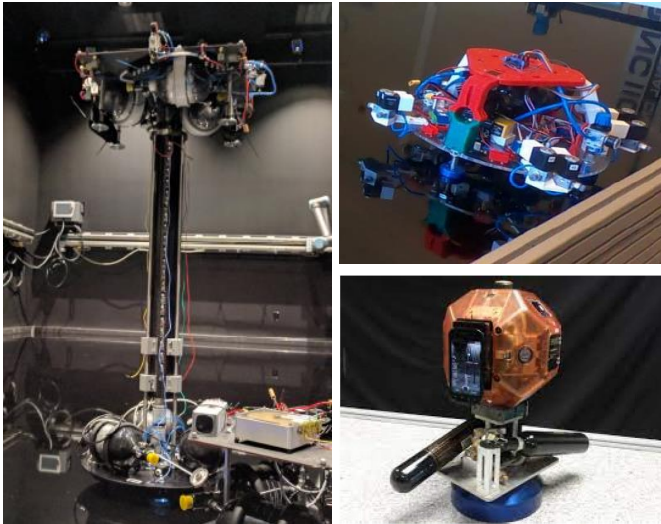

Our goal

- Simple
- Small
- Long operation time
- Refillable
- Actuation for mass and inertia compensation



We need a Robot !

Schematic diagram

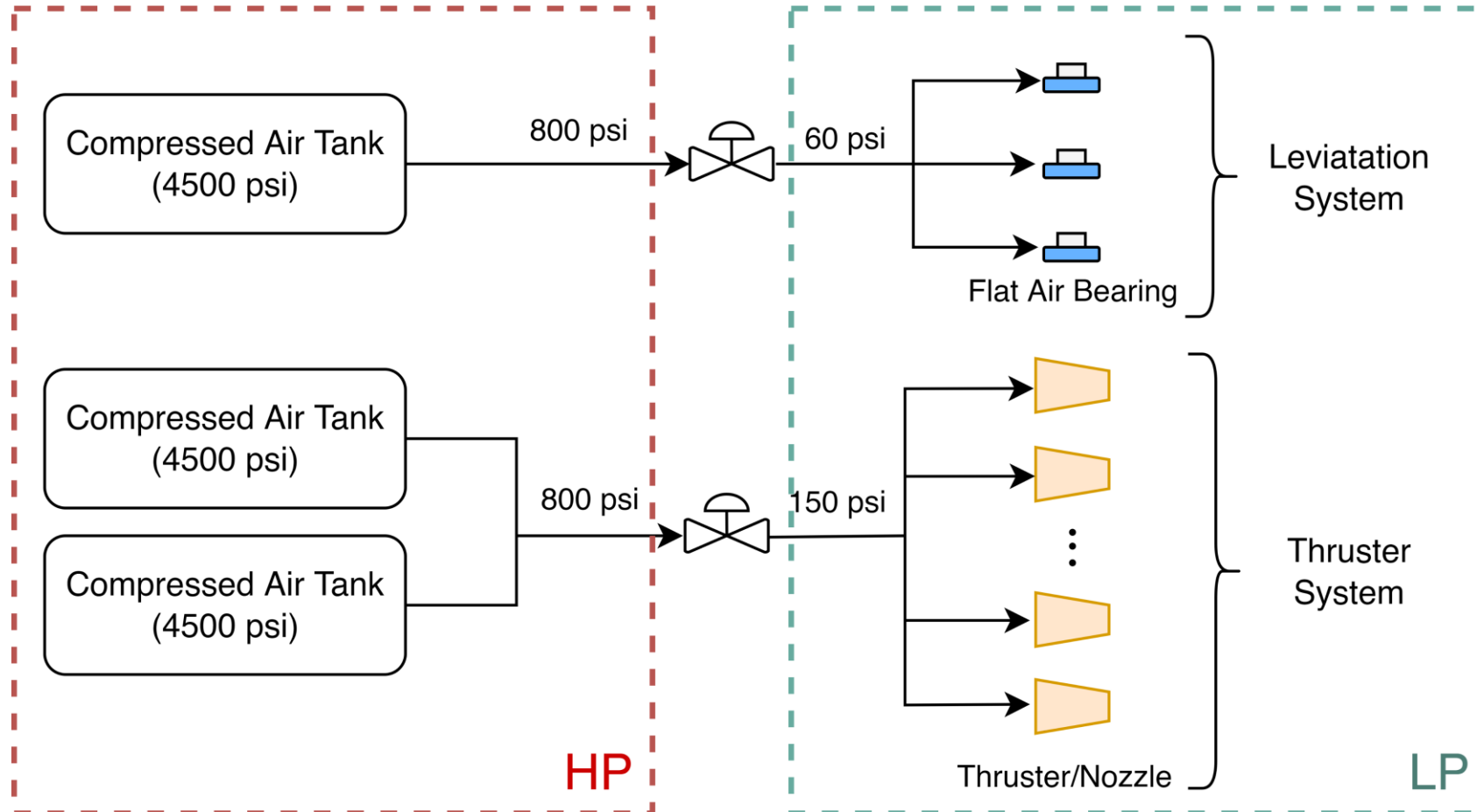

Iterations of the air carriage

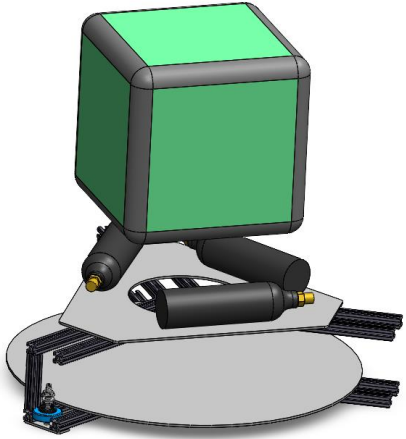

1

Iterations of the air carriage

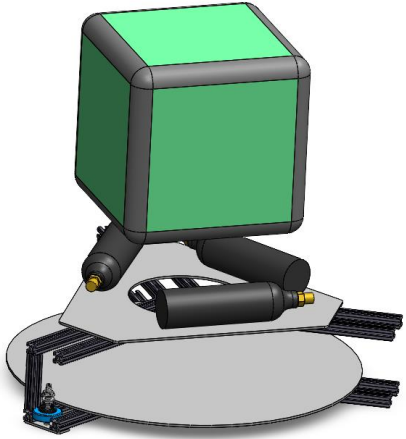

1

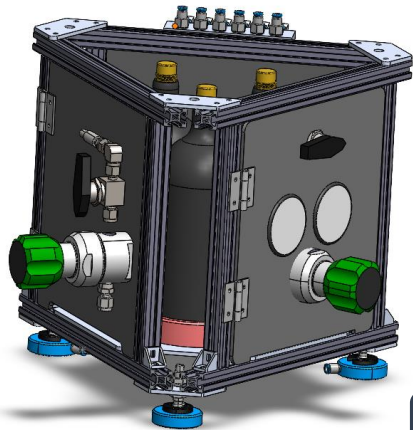

2

Iterations of the air carriage

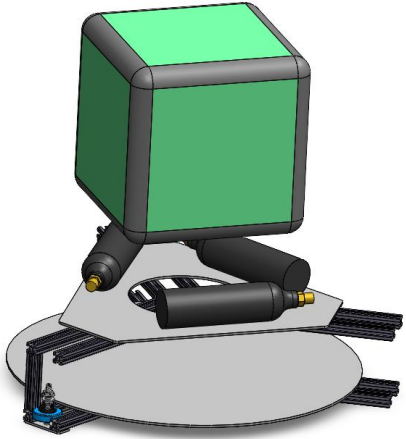

1

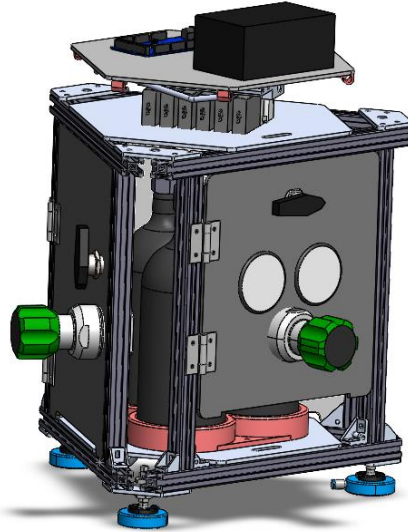

2

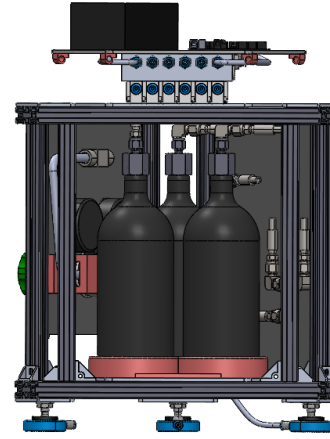

3

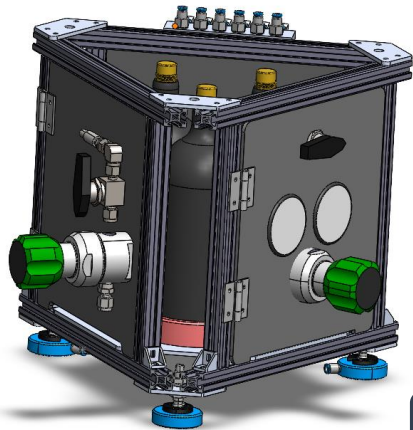

Iterations of the air carriage

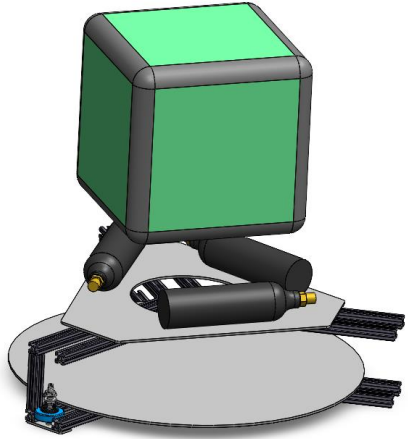

1

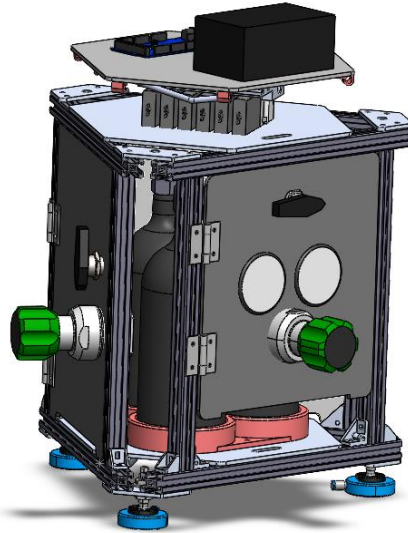

2

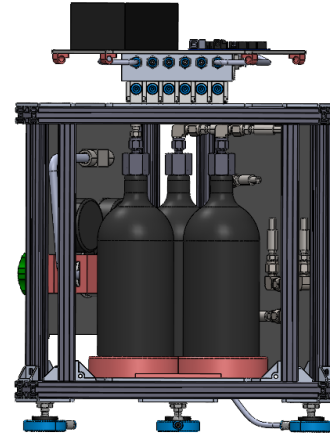

3

Final!

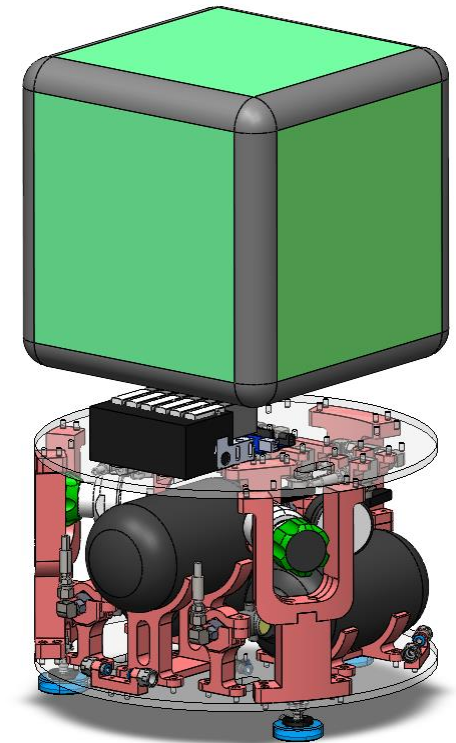

Final Design

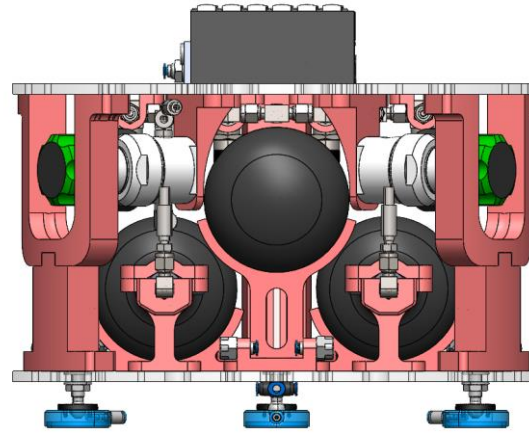
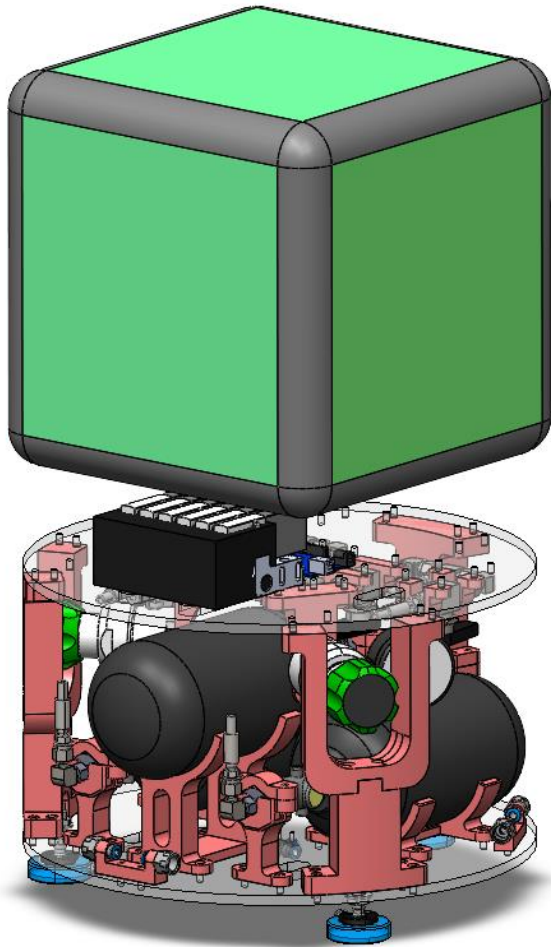

Front

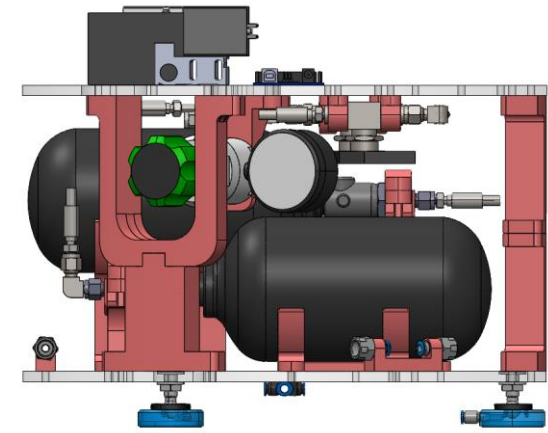

Right

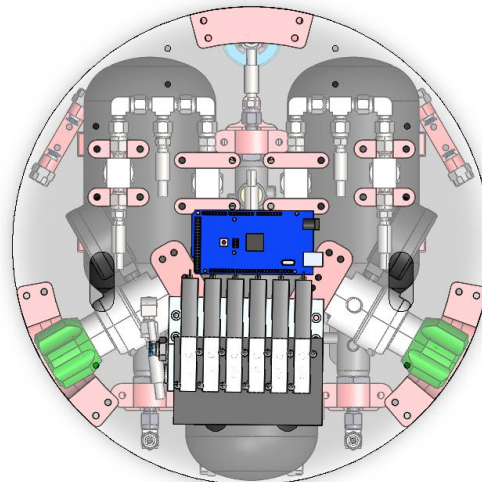

Top

Final selection

- 3 Air tanks
- 3 Bearings
- 6 Actuators

Simulation

Control
Algorithm

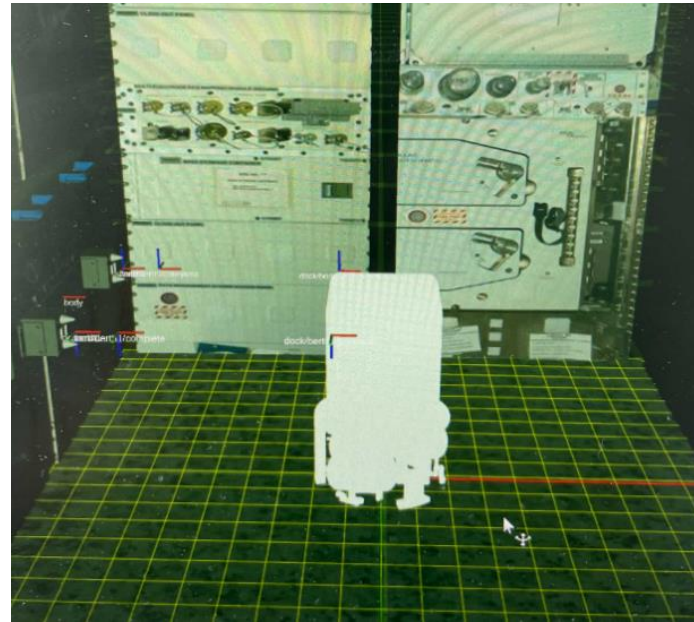
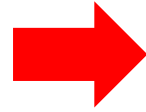

Gazebo simulation

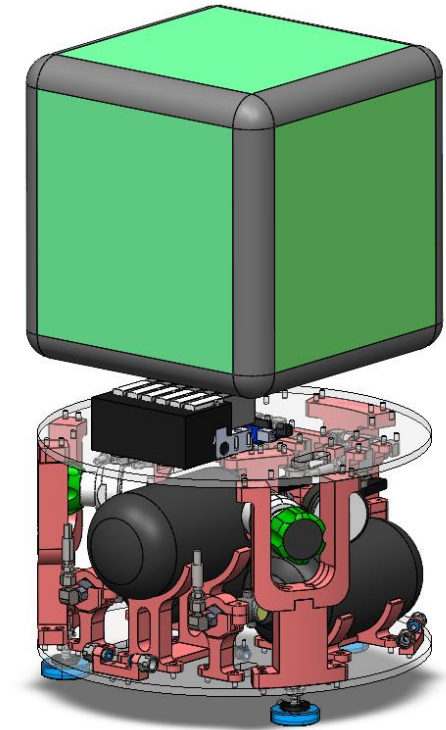
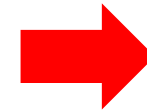

Real Robot

Prototype

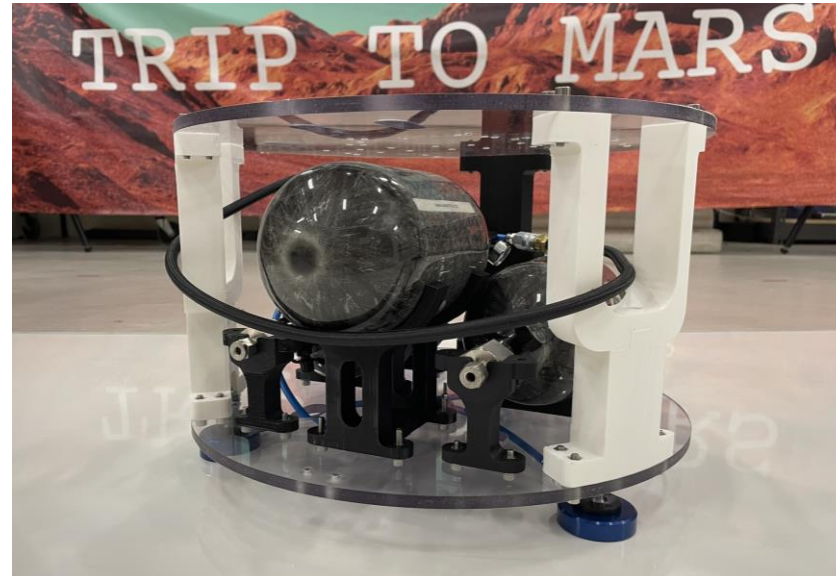
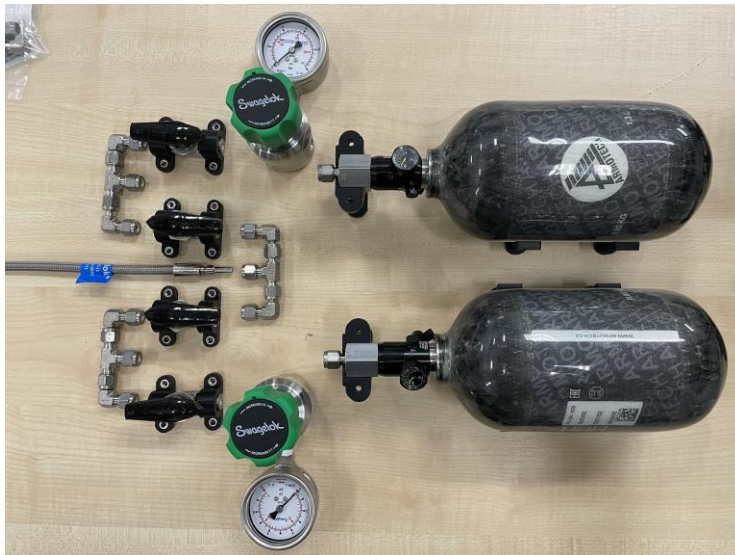

Thank You!

